

MX.250.P003

0,03 - 0,3 %

2,5
m³/h

Massima portata motore
Maximum motor flow rate



ITA QUOTE (mm) | GB DIMENSIONS (mm)

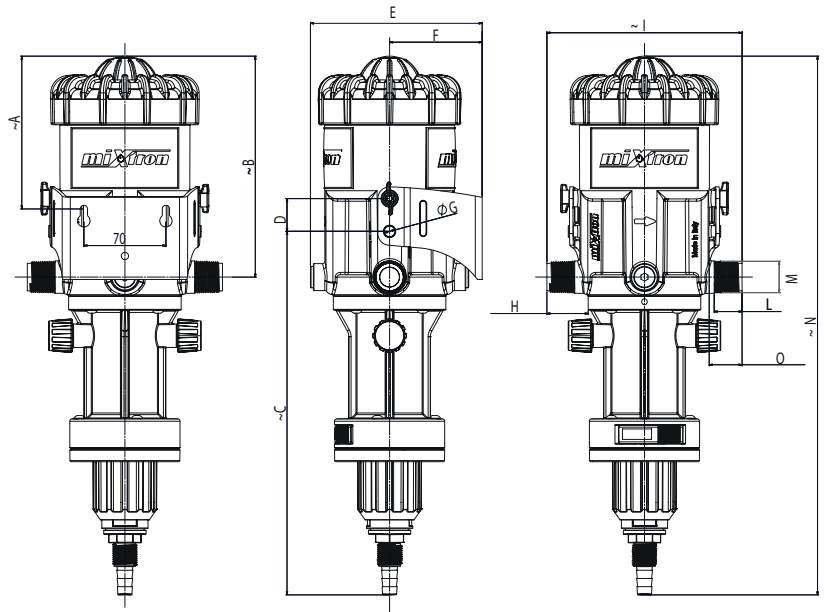

	mm	inches		mm	inches		mm	inches
A	130	5,12	F	79	3,11	M	3/4" BSPT	3/4" BSPT
B	188,5	7,42	G	Ø 10	Ø 0,39	N	~ 460	~ 18,11
C	310,1	12,21	H	35,3	1,39	O	28	1,1
D	28	1,1	I	~ 166,5	~ 6,56			
E	164,5	6,48	L	23,8	0,94			

ITA CARATTERISTICHE | GB CHARACTERISTICS

Dosaggio min/max %
Min/Max dosing ratio %

0,03 - 0,3 %

Min/Max rapporto dosaggio
Min/Max dosing ratio

1:3000 ; 1:350

Max portata motore
Max water flow

2.500 l/h

Componenti plastici
Plastic components

POM, PP, HDPE, PA12

Componenti metallici
Metal components

AISI 316, Duplex

Guarnizioni
Seals

Viton, EPDM

Pressione di lavoro
Operating pressure

0,3 - 6 bar

Massima pressione statica
Max static pressure

10 bar

Temperatura
Temperature

5° - 40° C

ITA Grafico perdite di carico - pompa 0,03% - 0,3%

GB Flow Resistance Graph - pump 0,03 % - 0,3%

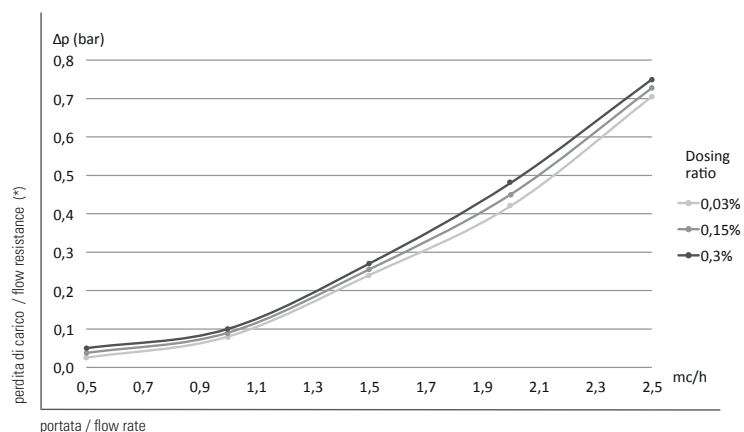

ITA VARIANTI E OPTIONAL | GB VARIANTS AND OPTIONAL

BYPASS

VERSIONE EXTREME / EXTREME VERSION

ON/OFF



Ulteriori informazioni tecniche disponibili su richiesta
Additional technical information available on request

miXtron